

[www.flkpump.com](http://www.flkpump.com)

本公司一直致力于不断开发改进产品，  
并对此拥有最终解释权。  
如图册与实物有不同之处，请以实物为准。

# FULANKE M & E

## 富兰克增氧机 **AERATOR**

[www.flkpump.com](http://www.flkpump.com)



### 浙江富兰克机电有限公司

**ZHEJIANG FULANKE M&E CO.,LTD.**

地址:中国.浙江省台州温岭市山市工业区康乐路

ADD:Kangle Road Shanshi Industrial Zone,Daxi Wenling,Zhejiang Province,China

内销部电话: 0576-86382738

Domestic Sales Telephone:0576-8638273

出口部电话: 0086-576-86308168

Overseas Sales Telephone:0086-576-86308168

传真: 0086-576-86388738

Fax:0086-576-86388738

邮编: 317522 P.C.: 317522

E-mail:sales@flkpump.com

<http://www.flkpump.com>





www. flkpump. com

# 企业概况 FULANKE COMPANY REGULATIONS

浙江富兰克机电有限公司是一家集研发、生产、销售、服务一体化的新型生产企业。成立于1992年，具有20多年的制造、销售经验。2011年9月获得出口生产型企业资格。

富兰克目前以生产水泵系了、电机系列、增氧系列、太阳能系列为主要的生产对象。公司建筑坐落于“水泵之乡”---大溪。拥有标准化花园式生产基地近百亩，建筑面积12000多平方米，在职员工200多人。作为一家发展迅速的水泵生产企业，富兰克拥有强大的营销网络，至2011年，由公司的第一经销商或第三方零售店铺运营商于中国经营的富兰克产品达1000多位。成熟的产销结合的品牌运营体系使其出口业务遍及欧洲、美洲、亚洲、非洲、澳洲五大洲10多个国家。

21世纪，富兰克人充满了信心接受挑战，使富兰克更具色彩、实现更高飞跃。

Zhejiang Fulanke M&C CO.,LTD.which one all can do Research, Product, Sells, Service a new kind product company. Found on 1992, have more than 20 years manufacture and sales experience. The submersible,2011compant became a exitment certification company.

Now Fulanke company main product serial of pumps, series of motors, seria of oxygenation, serial of solar energy. Company building standing on named"water pumps town"—DaXi.Possession like garden standardization nearly about 100mu production base. More than 12000 square construction area. Have more than 200 employees.

As a fast development of pump production company. Fulanke have a strong marking network. To 2011,buy the distributor, or third-party retail shop operators to China in Fnlanke products more than 1,000.Mature producture and sells of brand management system that the export business in Europe and America,Asia,Africa,and Australia five continents have more than 10 countries. The 21st century, Fulanke who full of confidence to accept challenge. Making Fulanke have more color and jumping highly.



## 荣誉证书 Certificate of honor

## 生产设备 Production equipment





YC-0.75 二叶轮水车式增氧机  
Two-Impeller paddle wheel aerator

YC-0.75 四叶轮水车式增氧机  
Four-Impeller paddle wheel aerator

YC-1.5 四叶轮水车式增氧机  
Four-Impeller paddle wheel aerator

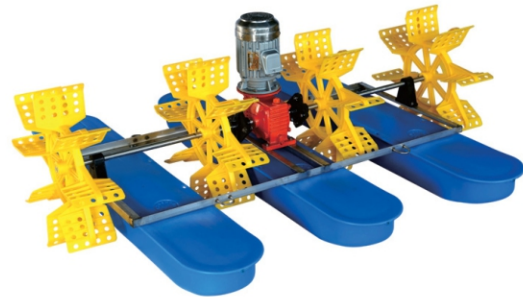

YC-1.5-1 四叶轮水车式增氧机  
Four-Impeller paddle wheel aerator

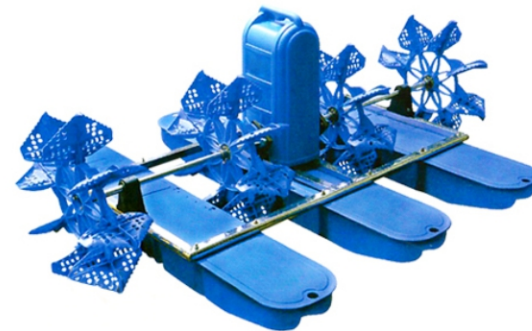

YC-1.5-2 四叶轮水车式增氧机  
Four-Impeller paddle wheel aerator

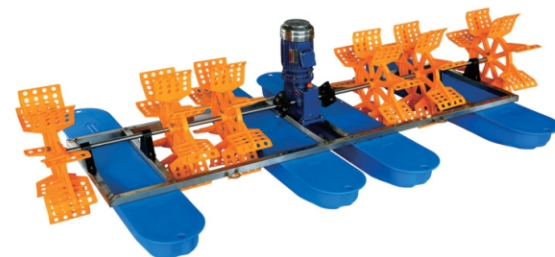

YC-1.5 六叶轮水车式增氧机  
Six-Impeller paddle wheel aerator

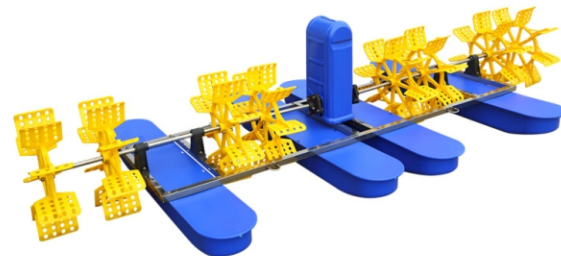

YC-2.2 八叶轮水车式增氧机  
Eight-Impeller paddle wheel aerator



YC-2.2 十二叶轮水车式增氧机  
Twelve-impeller paddle wheel aerator

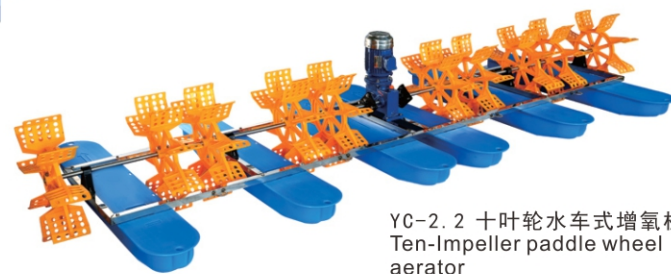

YC-2.2 十叶轮水车式增氧机  
Ten-Impeller paddle wheel aerator



产品概述/Product introduction:

- 1、减速箱采用弧形伞齿轮，替代涡轮蜗杆，节能高效，比传统机型节电20%以上
- 2、弧形伞齿轮采用铬锰钛合金钢制作，表面碳氮共渗，硬度高，使用寿命长；
- 3、采用机械密封，确保无漏油污染；
- 4、电机内装保护器，避免电机意外烧坏；
- 5、整机塑料浮船，尼龙叶轮，不锈钢转轴和支架。

1. Arcuate bevel-gear instead of worm gear is adopted for reducer, causing energy saving and higher efficient, saving over 20% energy than traditional models;
2. Arcuate bevel-gear is made of chromium-manganese-titanium alloyed steel with carbonitriding on the surface, adding rigidity and providing longer service life;
3. Mechanical seal is used to ensure no oil leakage pollution;
4. Protector is installed inside the machine to avoid motor being burnt accidentally;
5. PE float, nylon impellers, stainless steel shaft and frame are available for customer to choose.

技术参数/Technical parameters

型号 Model	功率 Power		电压 Voltage V/50Hz	动力效率 Power efficiency (kg/kW.h)	溶氧量 DO (kg/hr)	电流 AMP (A)	整机重量 Weight (kg)	40尺集装箱 40 Container set
	千瓦 kW	马力 HP						
YC-0.75 (2叶) 有效水深Effective water flow: 50m	0.75	1	220	≥ 1.25	≥ 1.6	1.25	80	185
YC-0.75 (2叶) 有效水深Effective water flow: 50m	0.75	1	380	≥ 1.25	≥ 1.9	1.25	80	185
YC-0.75 (4叶) 有效水深Effective water flow: 50m	0.75	1	220	≥ 1.25	2.3~2.6	1.60	80	185
YC-1.5 (4叶) 有效水深Effective water flow: 50m	1.5	2	380	≥ 1.25	2.6~2.9	2.45	100	133
YC-1.5 (4叶) 有效水深Effective water flow: 50m	1.5	2	380	≥ 1.25	2.8~3.1	2.45	100	133
YC-1.5 (6叶) 有效水深Effective water flow: 50m	1.5	3	380	≥ 1.5	3.6~3.8	2.60	120	66
YC-2.2 (8叶) 有效水深Effective water flow: 50m	2.2	3	380	≥ 1.5	3.6~3.8	2.60	120	66
YC-3 (10叶) 有效水深Effective water flow: 50m	2.2	3	380	≥ 1.5	4.0~4.3	2.80	125	63
YC-3 (12叶) 有效水深Effective water flow: 50m	3	4	380	≥ 1.5	4.3~4.6	3.0	135	60

可根据客户要求制作不同电压、频率、功率的增氧机  
We can design the different voltage power and HZ according to customers requirement.



0.75kW硬油封4键(90-ABB式)  
Hard oil seal, 4 spline  
(90-ABB type)



1.5kW硬油封4键  
(90-ABB式)  
Hard oil seal, 4 spline  
(90-ABB type)



4马力硬油封9键(3kW)  
4-horsepower hard oil seal,  
9 spline (3kW)



不锈钢罩-硬油封4键  
(90-普通电机筒式)  
Stainless steel cover-hard oil  
cover, 4 spline(90-general motor  
cylinder type)



大齿轮箱-硬油封4键  
(100-西瓜筒式)  
Big gearbox-hard oil seal, 4  
spline (100-watermelon-barrel  
type)



单相220V主机  
Single-phase 220V main unit



机械油封9键(ABB式)  
Mechanical oil seal, 9 spline  
(ABB type)



机械油封9键(台式)  
Mechanical oil seal, 9 spline  
(Taiwan-type)



机械油封9键(西瓜筒式)  
Mechanical oil seal, 9 spline  
(watermelon-barrel type)



尼龙罩-硬油封4键(90-  
普通电机筒式)  
Nylon cover-hard oil seal,  
4 spline (90-general motor  
cylinder type)



硬油封9键(大齿轮箱-ABB式)  
Hard oil seal, 9 spline  
(big gearbox-ABB type)



硬油封4键(100-ABB式)  
Hard oil seal, 4 spline  
(100-ABB type)



小齿轮箱-硬油封9键(100-西瓜筒式)  
Small gearbox-hard oil seal,  
9 spline (100-watermelon  
barrel type)



涡轮式9键  
Turbo type, 9 spline



涡轮式9键(齿轮箱)  
Hard oil seal, 9 spline  
(gearbox)



硬油封9键(齿轮箱)  
hard oil seal,  
9 spline(gearbox)



硬油封4键(小齿轮箱)  
Hard oil seal, 4 spline  
(small gearbox)



硬油封9键(齿轮箱)  
Hard oil seal,  
9 spline (gearbox)



机械油封9键(齿轮箱)  
Mechanical oil seal, 9 spline  
(gearbox)

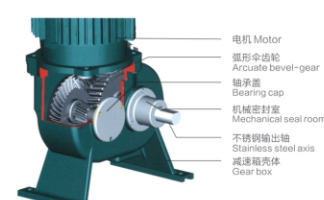

4键齿轮套件  
4-spline gear kit

电机 Motor  
弧形伞齿轮 Arcuate bevel-gear  
轴承盖 Bearing cap  
机械密封室 Mechanical seal room  
不锈钢输出轴 Stainless steel axis  
减速箱体 Gear box



水车式9键4马力电机(中式)  
Paddlewheel, 9 spline,  
4-horsepower motor  
(Chinese type)



水车式9键3马力电机(西瓜筒式)  
Paddlewheel, 9 spline,  
3-horsepower motor  
(watermelon-barrel type)



水车式9键2马力电机(西瓜筒式)  
Paddlewheel, 9 spline,  
2-horsepower motor  
(watermelon-barrel type)



水车式9键2马力电机(台式)  
Paddlewheel, 9 spline,  
2-horsepower motor  
(Taiwan-type)



水车式9键2马力电机(东元式)  
Paddlewheel, 9 spline,  
2-horsepower motor  
(dongyuan type)



水车式9键2马力电机(ABB式)  
Paddlewheel, 9 spline,  
2-horsepower motor (ABB type)



水车式4键2马力电机(中式)  
Paddlewheel, 4 spline,  
2-horsepower motor  
(Chinese type)



水车式4键1马力电机(中式)  
Paddlewheel, 4 spline,  
1-horsepower motor  
(Chinese type)



水车式4键1马力电机(单相)  
Paddlewheel, 4 spline,  
1-horsepower motor  
(single-phase)



水车式4键1马力电机(ABB式)  
Paddlewheel, 4 spline,  
1-horsepower motor  
(ABB type)



1号 滚珠轴承座  
Size-1 ball bearing  
base



2号 台式尼龙轴承座  
Size-2 bench-type  
nylon bearing base



3号 尼龙轴承座  
Size-3 nylon  
bearing base



4号 尼龙轴承座  
Size-4 nylon  
bearing base



5号 台式尼龙轴承座  
Size-5 bench-type  
nylon bearing base



6号 尼龙轴承座  
Size-6 nylon  
bearing base



7号 中式轴承座  
Size-7 Chinese-type  
bearing base



1号中式防水罩  
Size-1 waterproof  
cover



2号台式防水罩  
Size-2 waterproof  
cover



1号连接  
Size-1 connection



2号连接  
size-2 connection



3号台式连接  
Size-3 connection



不锈钢连接  
Stainless steel connection



不锈钢活动接头  
Stainless steel movable joint



小号中式铸铁活动接头  
Small-size Chinese-type cast iron movable joint



大号中式铸铁活动接头  
Big-size Chinese-type cast iron movable joint



大号台式铸铁活动接头  
Big-size bench-type cast iron movable joint



齿轮套件  
Spline gear kit



1号 Φ68cm整体叶轮  
Size-1 Φ68cm integral impeller



2号 Φ67cm整体叶轮  
Size-2 Φ67cm integral impeller



3号 Φ66cm整体叶轮  
Size-3 Φ66cm integral impeller



4号 Φ66cm分体叶轮  
Size-4 Φ66cm split impeller



5号 Φ68cm分体叶轮  
Size-5 Φ68cm split impeller



6号 Φ66cm分体尼龙叶轮  
Size-6 Φ66cm nylon split impeller



台式四号浮船长度 Length1.77m  
重量Weight7.0kg  
Size 4 Taiwanese Models Float boatLength1.77mWeight7.0kg



中式一号浮船长度 Length1.63m  
重量 Weight5.5kg  
Size 1 Float boatLength1.63m Weight5.5kg



中式二号浮船长度 Length1.66m  
重量Weight6.0kg  
Size 2 Float boatLength1.66m Weight6.0kg



台式三号浮船长度Length1.75m  
重量Weight7.0kg  
Size 3 Taiwanese Models Float boatLength1.75mWeight7.0kg



2马力中式不锈钢方架  
2-horsepower Chinese-type stainless steel square frame



2马力中式不锈钢半圆架  
2-horsepower Chinese type stainless steel square frame



2马力台式不锈钢支架(带吊环)  
2-horsepower bench-type stainless steel frame (with rings)



1马力中式不锈钢方架  
1-horsepower Chinese type stainless steel square frame



1马力台式不锈钢支架(带吊环)  
1-horsepower bench-type stainless steel frame (with rings)



不锈钢传动轴  
Stainless steel shaft

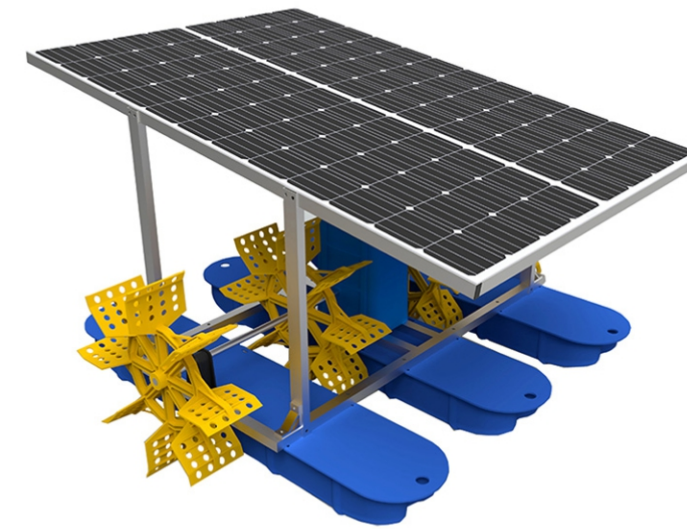

太阳能增氧机整体相结合相结合，使它可以应用到任何地方，而不用担心电力的限制。  
灵活: eO2+是一个可扩展的解决方案，因为它可以单独使用，也可以一起使用，因为它具有创新性、独立和高效的设计。  
免维护: 由于先进的系统设计、合格的材料和严格的质量，高可靠性和免维护。控制会带来更好的可持续性。  
eO2+系统是一种创新的解决方案，作为一种便携式、可靠、方便的氧气曝气(养鱼户、虾农)、水质改善和其他一些应用。

Solar aerator integrated make it can be applied to anyplace without fear of the limits of electricity.  
Flexible: eO2+ is a scalable solution, as it can be used alone or together, due to its innovative, independent and high-efficient design.  
Maintenance-free: High reliable and maintenance-free due to advanced system design, qualified materials and stringent quality control lead to a better sustainability  
The eO2+ System is an innovative solution as a portable, reliable, and convenient re-source for oxygen aeration (fish farmer, shrimp farmer), water quality improvement and some other applications.

Power	Voltage	Dynamic efficiency	Aerobic capacity	Load area	Weight
400 W	DC 24 V	≥ 1.25 kg(h.w)	≥1.7 kg/h	2000-6500 m <sup>2</sup>	70 kg
650 W	DC 24 V	≥ 2.00 kg(h.w)	≥2.1kg/h	7000-27000 m <sup>2</sup>	80 kg



YL-叶轮式增氧机(3千瓦)  
YL-impeller aerator (3 kW)

YL-叶轮式增氧机(1.5千瓦)  
YL-impeller aerator (1.5 kW)



产品特点/Product characteristic:

- 1、电机内装保护器，当三相电源缺相或电机过热时会自动跳开，以免电机意外烧坏；
  - 2、齿轮采用铬锰钛合金钢材料，齿面经碳氮共渗，大大延长使用寿命；
  - 3、根据不同使用环境和用户的特殊要求，开发出工程塑料叶轮和不锈钢叶轮，确保在海水或腐蚀性较强之工业废水中长期使用、无需经常更换叶轮或刷漆。
1. With a built-in protector, the motor turns off automatically when overheated or when the three-phase mains loses a phase, so as to protect the motor from burning out;
  2. The gear is made of chromium-manganese-titanium alloy steel, with carbonitriding on the surface, which can prolong life span greatly;
  3. To ensure durable use in the sea water or highly erosive industrial waste, engineering plastic impeller and stainless steel impeller are developed according to the requirements of varied usage environments and specific demands of users, eliminating the need of frequent change of impellers or painting.

技术参数/Technical parameters

型号 Model	功率 Power		电压 Voltage V/50Hz	增氧能力 Oxygen transfer capacity kg/h	动力效率 Power efficiency kg/kW.h	负荷水面 Loading Area (亩)	整机重量 Weight kg
	千瓦 kW	马力 HP					
YL-3	3	4	380	≥4.8	≥1.5	8-12	79
YL-2.2	2.2	3	380	≥3.7	≥1.5	6-10	60
YL-1.5	1.5	2	380	≥2.6	≥1.5	4-8	52
YL-1.5	1.5	2	220	≥2.6	≥1.5	3-6	52
YL-1.1	1.1	1.5	220	≥1.8	≥1.4	3-4	52
YL-0.9	0.9	1.25	220	≥1.4	≥1.4	1-3	50

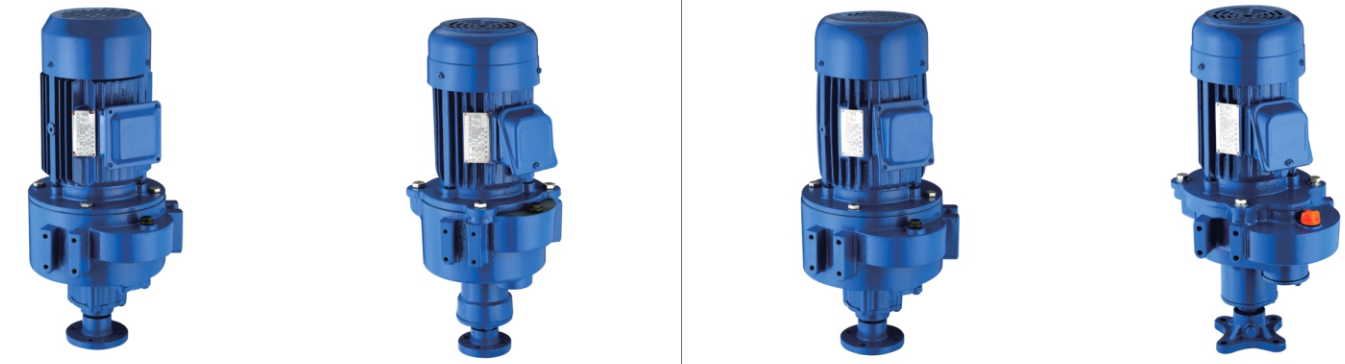

大圆箱3kW主机  
Big round box 3kW  
main unit

广式1.5kW主机  
Guangdong-type 1.5kW  
main unit

西瓜筒式3kW主机  
Watermelon-barrel type 3kW  
main unit

中式1.5kW大箱主机  
Chinese-type 1.5 kW  
big-cabinet main unit



中式1.5kW单相主机  
Chinese-type 1.5 kW  
single-phase main unit

中式1.5kW主机  
Chinese-type 1.5 kW  
main unit

中式3kW主机  
Chinese-type 3kW  
main unit

大圆箱3kW齿轮箱  
Big round box 3kW  
gearbox

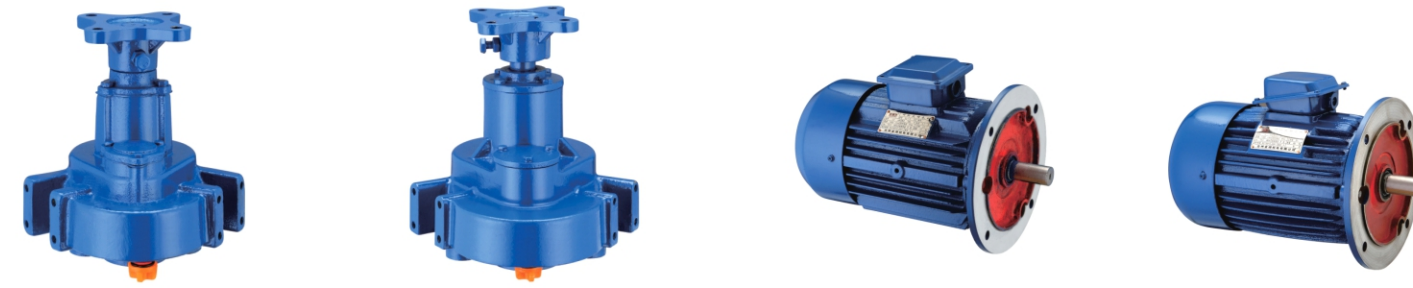

中式1.5kW齿轮箱  
Chinese-type 1.5kW  
gearbox

中式3kW齿轮箱  
Chinese-type 3kW  
gearbox

ABB式3kW电机  
ABB-type 3kW  
motor

西瓜筒式3kW电机  
Watermelon-barrel type 3kW  
motor

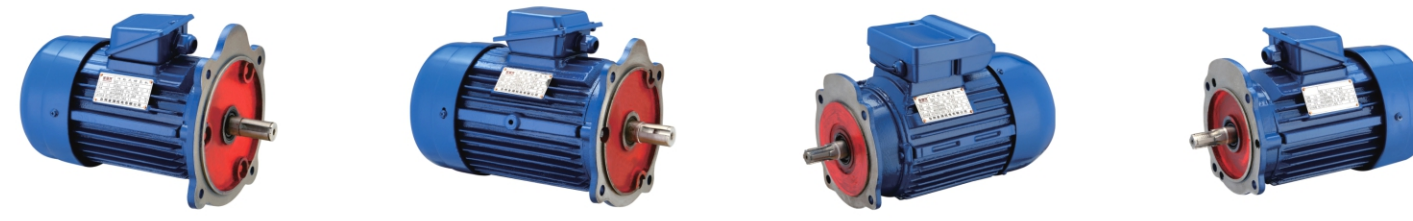

中式1.5kW电机  
Chinese-type 1.5kW  
motor

中式3kW电机  
Chinese-type 3kW  
motor

叶轮式4键0.75~1.5kW单相电机  
Impeller-type 4-spline 0.75~1.5kW  
single-phase motor

叶轮式4键1.5kW电机  
Impeller-type 4-spline 1.5kW  
motor



3千瓦浮球  
Size-1 3kW float



2号 1.5千瓦浮球  
Size-2 1.5kW float



1号 不锈钢支架  
Size-1 stainless steel bracket



2号 中式镀锌支架  
Size-2 Chinese-type galvanized bracket



3号 大圆箱镀锌支架  
Size-3 big round box galvanized bracket



4号 中式喷塑支架  
Size-4 Chinese-type plastic-sprayed bracket



5号 大圆箱喷塑支架  
Size-5 big round box plastic-sprayed bracket



1号 防水罩  
Size1 waterproof cover



2号 防水罩  
Size 2 waterproof cover



3号 防水罩  
Size 3 waterproof cover



4号 防水罩  
Size 4 waterproof cover

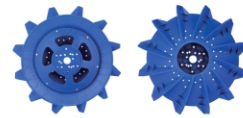

分体3kW大号塑料叶轮 Φ76cm  
Split 3kW large-size plastic impeller Φ76cm

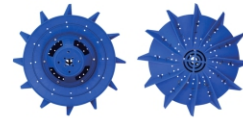

广式1.5kW塑料叶轮 Φ66cm  
Guangdong-type 1.5kW plastic impeller Φ66cm

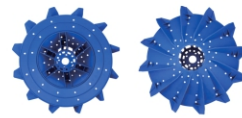

连体2.2-3kW塑料叶轮 Φ73cm  
Integrated 2.2-3kW plastic impeller Φ73cm

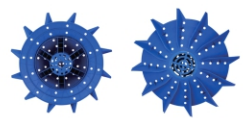

中式1.5kW塑料叶轮 Φ66cm  
Chinese-type 1.5kW plastic impeller Φ66cm



镀锌双叶轮 Φ73CM  
Galvanized double impeller Φ73cm



广式镀锌叶轮 Φ67CM  
Guangdong-type galvanized impeller Φ67cm

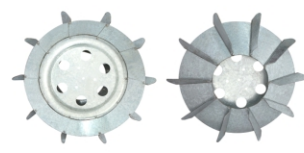

中式1.5kW镀锌叶轮 Φ68cm  
Chinese-type 1.5kW galvanized impeller Φ68cm



中式3kW镀锌叶轮 Φ76cm  
Chinese-type 3kW galvanized impeller Φ76cm



新款浮水泵  
New float pump

产品概述/Product introduction:

排灌增氧浮式水泵，由浮式水泵和增氧喷头组成。装上喷头能增氧，拆去喷头又可作农田排灌用，两种功能的转换无需任何工具。悬浮于水中的浮水泵吸入下层贫氧水，从喷头喷出形成喷泉急速射向空中，分散成大小不等的水滴，与空气充分接触，增加溶解氧，落回鱼池，在水面形成一圈“暴雨”，冲击水面，产生较好的增氧效果。

This pump is composed of floating pump and aeration nozzle. it is both available for aeration by fitting the nozzle and farmland irrigation and drainage by dismantling the nozzle, such conversion between the two functions can be done without any tool. The floating pump suspended in the water draws the oxygen-depleted water at the lower level, and spray it from the nozzle upward into the sky rapidly, which forms a fountain and is dispersed into droplets of varying sizes in contact with the air to increase dissolved oxygen, and then falls back to the fish pond to form a circle of "torrential rain" impacting the water surface to achieve better aeration.

技术参数/Technical parameters

型号 Model	功率 Power (kW)	电压 Voltage V/50Hz	最高扬程 Max.head ≥m	最高流量 Max.Flow ≥m³/h	电泵效率 Efficiency (%)	配管内径 Inch/mm	重量 Weight kg
FBD-2.2	2.2	380 (三相)	5	55	49	4"/100	20
FB-1.8	1.8	220 (单相)	4	55	46	4"/100	20
FBD-1.5	1.5	380 (三相)	7	40	49.3	3"/80	16
FB-1.5	1.5	220 (单相)	6	30	47.5	3"/80	16
FBD-1.1	1.1	380 (三相)	7	30	48.9	3"/80	16
FB-1.1	1.1	220 (单相)	7	30	47.6	3"/80	16
FBD-0.75	0.75	380 (三相)	9	9	36.7	2"/50	15
FB-0.75	0.75	220 (单相)	8	8	34.4	2"/50	15





产品概述/Product introduction:

曝气涌浪式增氧机，其设计简单，轻便，最大的优点省电。增氧原理与叶轮式和水车式不同，独特的花朵状螺旋形叶轮，配合独特浮筒设计，能使输出的水向上喷发，造成一定区域的水体为沸腾状及水体涌浪，因而提高水在喷发过程中与空气的接触，从而提高水体的溶氧量。其次，水在向上喷发的同时直接穿越电机和减速机，使电机与减速机在水的冷却下，电机长时间工作不发热，排除了电机因长时间运转发热增大电流，烧坏的通病，并且能在300-350V的超低电压下正常运转。

造浪功能：强大的造浪能力，大大提高了水体与空气接触面积。并通过曝气，空气接触和藻类光合作用，紫外线辐射等途径，使整个水体载氧量增加，改善水质，减少污水排放。

提水能力：具有强大的提水能力（把底层水换到表面并沿水面输出），有效降低水体中氨氮、亚硝酸盐、硫化氢、大肠杆菌等有害物质及气体的含量，改善池塘底质，遏制水体污染。

Surge aerator of simple and light design has the biggest advantage of power saving. Being different from impeller and paddle wheel aerators, its aeration principle lies in the unique flower-shaper spiral impeller fit with the unique float-bowl design, which can make the output water erupted upward to create a certain area of water body like boiling water and surge, there by increasing the water contact with the air during eruption the enhance the dissolved oxygen in the water. Secondly, the water goes around the motor and the reduce, allowing long hours running thanks to optimum water colling, so as to eliminate problems like being burnt out, increased current and overheating after the long time running. This aerator can operate normally at the low voltage of 300-350V.

Wave-making function: strong waving function greatly increases contact area between water and air. And through such ways as aeration, air contact and algae photosynthesis, ultraviolet radiation, it allows to increase the oxygen-carrying capacity, improve the water quality and reduce the sewage discharge. reduces the content of such harmful substances and gasess as ammonia chloride, nithit, hydrogen sulfide, colibacillus, so as to improve quality of the pondsediment and inhibit pollution to the water body.



技术参数/Technical parameters

型号 Model	功率 Power	电压 Voltage V/50Hz	动力效率 Power efficiency kg/kw.h	增氧能力 Oxygen increasing capacity	负荷水面 Loading Area (亩)	整机重量 Weight kg
YLZ0.75	0.75	380	1.5	2.5	4-6	38
YLZ1.5	1.5	380	1.5	2.74	6-8	40

## 行星齿涌浪式增氧机 Wave maker

采用汽车发动机、飞机引擎里面用的行星齿轮减速技术，它不仅能提高输出扭矩，还降平衡了转轴输出，这样让负载更加平稳，噪声减少。池里浪花更容易表面溶氧速度，调节上下水温，更有利于水质调制。  
Pond wave making accelerate oxygen dissovle rate, modulate upper and lower water temperature, and improve water quality.



主要部件/Main Parts List

部件名称 Part description	数量Quantity
减速马达 Reducer and motor	1set
浮船Round float	1pc
水罩PP cover	1pc
连接法兰Support plate	1pc
拉杆Tie bar	2pcs
拉杆固定片Fixed flap	2pcs
叶片Nylon impeller	4pcs
螺丝包Screw bag	1pc



技术参数/Technical parameters

型号 Model	功率 Power	增氧能力 Oxygen increasing capacity	动力效率 Power efficiency	提水能力 Pumping capacity	造浪强度 Wave making strength	叶轮速度 Impeller speed	外形尺寸 Dimensions	整机重量 Weight	使用范围 Farming coverage
YYL-0.75	0.75KW	≥0.96kgO <sub>2</sub> /h	1.2kgO <sub>2</sub> /h*KW	≥5000m <sup>3</sup> /h	波浪40MM的波浪作用范围(直径)≥60M Wave action of wave 40MM The range (diameter) is greater than 60M.	34转/分钟 34rpm	φ1580*900mm	53kg	4亩 2664m <sup>2</sup>
YYL-1.5	1.5KW	≥1.35kgO <sub>2</sub> /h	2.4kgO <sub>2</sub> /h*KW	≥7,200m <sup>3</sup> /h	波浪50MM的波浪作用范围(直径)≥70M Wave action of wave 50MM The range (diameter) is greater than 70M.	34转/分钟 34rpm	φ1680*900mm	55kg	6亩 4002m <sup>2</sup>





产品概述/Product introduction:

- 1、突破性机械设计提供水产养殖者最佳的供氧设备。
  - 2、最适合咸水和淡水养殖，以及工业废水处理用。
  - 3、提供高溶氧水准，平衡水温，净化水质及制造强劲水流、增加养殖收成量及较佳的水质管理。
  - 4、高耐度、强度品质、延长使用寿命；抗酸碱、日晒及咸水腐蚀。
  - 5、零件少、易装置、操作零故障、维修容易、成本低。
  - 6、体轻、易组合、装置和搬移。
1. Provide the best oxygen-supply equipment to aquaculture famers with its innovation machinery design.
  2. Suitable for salt and fresh water culturing and industrial waste water ineatment.
  3. Provide a high level of dissolved oxygen, balance the water temperature, purify the water and make strong water flow, increase aquaculter yleids and improve water quality management.
  4. High durability and high strength proiong the service life; resistance of acid and alkalinity, sun exposure and salt water erosion.
  5. Reduced number of mompanents make it easy to install, zero fault in handing, easy mainiten andce and low cost.
  6. Light weight, easy to assemble, install and move.



浮船  
Float boat



不锈钢叶轮  
Stainless steel impeller



尼龙网罩  
Nylon net cove



不锈钢网罩  
Stainless steel net cove

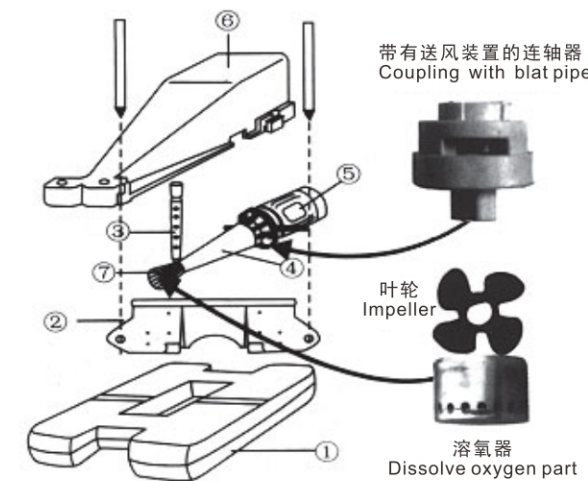

技术参数/Technical parameters

规格表 Specification	型号Model	YSL-1.5
	电机Phase	三相
	功率Power	1.5KW
	级数Poles	2极
	叶轮数Impeller amount	1
	外形尺寸Dimensions	1280L*740W*900H
	装运体积Stowage Volume	0.40m3
	40尺货柜可装数量 QTY per 40ctnr	180台
	增氧能力Ability of increasing oxygen	0.70kg/h
	动力效率Dynamic efficiency	0.82kg/kw.h
绝缘电阻Insulated resistance	200mΩ	

零件表/Spare parts

①浮船 Float boat	②支撑杆 Support tempate	③调整杆 Adjustment Bar	④主机 Host Volume	⑤马达 Moror	⑥外盖 Cover	⑦叶轮 Impeller
32x19x160		Φ30x510L	Φ122x596L	2HPx2P	810Lx290Wx280H	Φ51x36H

型号	功率	电压 (V)	转速	增氧能力	浮船数	负荷水面	重量
SL-1.1	1.1KW	380	110	》1.7	2组	3-5亩	75KG
SL-1.5	1.5KW	380	110	》2.5	2组	3-5亩	85KG
SL-3.0	3.0KW	380	110	》2.7	2组	3-5亩	90KG

柴油机驱动的多叶轮水车式增氧机  
Multi-impeller paddle wheel aerator drove by diesel



产品概述/Product introduction:

柴油机驱动多叶轮水车式增氧机系富兰克公司专为缺电地区水产养殖而研制的多叶轮增氧机。该机采用小型柴油机为动力源，通过减速箱变速，带动10-16套水车叶轮拨水，驱使水体流动，溶入氧气，分解有害物质，改善池塘水质，是水产养殖户的好帮手。

柴油机驱动多叶轮水车式增氧机主动力部分安放在塘基上，通过万向节将动力传递至旋转轴上，带动叶轮工作，叶轮工作速度在100-130转/分钟时效果更佳。

柴油机选用8-12匹小型机，该增氧机起动轻巧，省油实用，拨水力强，增氧效果显著，尤其适用池塘面积较宽较大的养殖户使用。



主机Host



传动轴 Transmission shaft



增氧排灌两用浮水泵

YFB鱼虾塘增氧排灌两用浮水泵

具有抽水、增氧双功能适用环境池塘。重量轻、噪声低、节能省电、使用方便。是新一代可适用于虾、鳗、蟹塘等特种水产养殖。具有净化水质，加溶氧量。

YFB fish and shrimp pond oxygenated drainage and irrigation floating pump

It has double functions of pumping water and increasing oxygen and is suitable for environmental ponds. Light weight, low noise, energy saving, easy to use. Is a new generation applicable to shrimp, Special aquaculture such as eel and crab pond. It has purified water quality and added dissolved oxygen.

增氧排灌两用浮水泵技术参数 Technical Parameters

型号Model	功率(kw)	扬程(m)	流量(m <sup>3</sup> /h)	电压(V)	配管内径mm(inch)	整机重量(kg)	转速(r/min)
YFB(D)750-5-25	0.75	5	25	220	75(3)	15	2800
YFB(D)1100-7-30	1.1	7	30	220/380	75(3)	16	2800
YFB(D)1500-7-40	1.5	7	40	220/380	75(3)	17	2800
YFB(D)1500-4-45	1.5	4	45	220	100(4)	19	2800
YFB(D)2200-5-50	2.2	5	50	220/380	100(4)	19	2800

型号Model	功率(kw)	电压(V)	叶轮数(Odd)	叶轮转速(r/min)	增氧功能(kg/h)	动力效率(kg/ch.kw)
YPYD-1.1*	1.1	220/380	4	2860	≥0.4	≥0.36
YPYD-1.5*	1.5	220/380	4	2860	≥0.72	≥0.36